



KREEPY KRAULY®

# PSP™-SERIES COMMERCIAL PLASTIC PUMPS



5PSP 3,5 - 4,5 - 5,5 HP



5PSP 7,5 - 10 HP

## FEATURED HIGHLIGHTS

- Self-priming pumps.
- Especially designed for swimming pool, aquatic and aquaculture applications.
- Seawater approved up to 4% salt concentration.
- Available with or without large pre-filter.
- Injection molded components of high quality glass-reinforced thermoplastic.
- CE & TUV approved, IP55 protected, IE2 compliant TEFC motor.
- Corrosion resistant, high grade stainless steel motor shaft.
- Included connections are metric slip fit 110mm ID inlet and 90mm ID - outlet for 3,5 to 5,5 HP versions and 110 mm ID outlet for 7,5 and 10 HP versions.
- High chemical resistance with all metal internal components being stainless steel.
- 2850 RPM Motor.

## ORDERING INFORMATION

Product	Voltage	HP	KW	Port Size Metric ISO / DIN INLET	Port Size Metric ISO / DIN OUTLET	Weight	BOX Dimensions (mm)
---------	---------	----	----	----------------------------------	-----------------------------------	--------	---------------------

### Three Phase Pool Pumps with PRE-Filter

5PSP-350-3	220-380V	3,50	2,60	110mm	90mm	32,40 Kg	860 x 375 x 600
5PSP-450-3	220-380V	4,50	3,30	110mm	90mm	35,30 Kg	860 x 375 x 600
5PSP-550-3	220-380V	5,50	4,00	110mm	90mm	35,50 Kg	860 x 375 x 600
5PSP-750-3	380-660V	7,50	5,60	110mm	110mm	68,60 Kg	950 x 445 x 635
5PSP-1000-3	380-660V	10,00	7,50	110mm	110mm	75,90 Kg	950 x 445 x 635

### Three Phase Pool Pumps without PRE-Filter

5PSP-350WS-3	220-380V	3,50	2,60	110mm	90mm	26,40 Kg	860 x 375 x 600
5PSP-450WS-3	220-380V	4,50	3,30	110mm	90mm	29,60 Kg	860 x 375 x 600
5PSP-550WS-3	220-380V	5,50	4,00	110mm	90mm	29,70 Kg	860 x 375 x 600
5PSP-750WS-3	380-660V	7,50	5,60	110mm	110mm	62,60 Kg	950 x 445 x 635
5PSP-1000WS-3	380-660V	10,00	7,50	110mm	110mm	69,90 Kg	950 x 445 x 635

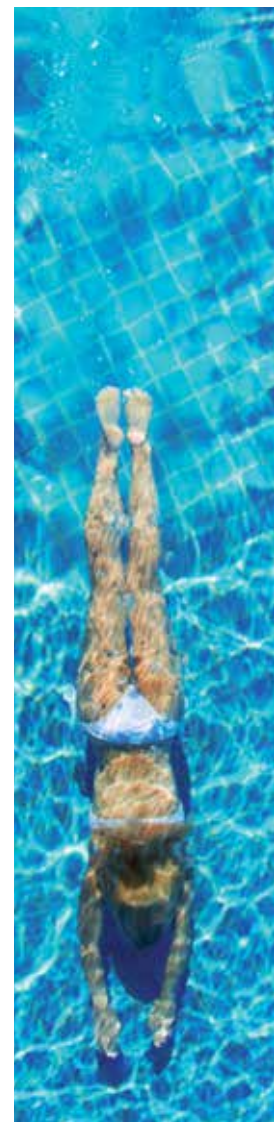

# PSP™-SERIES

## COMMERCIAL PLASTIC PUMPS

### DIMENSIONS AND PERFORMANCES

Performance Curve

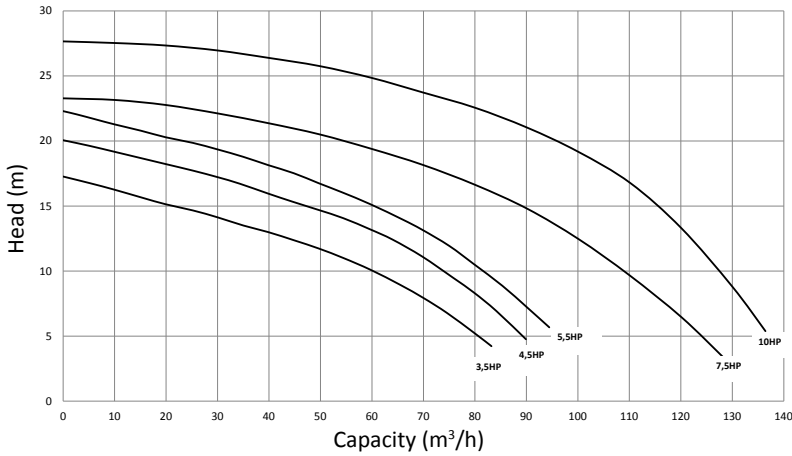

Pre-filter Flow & Loss Curve

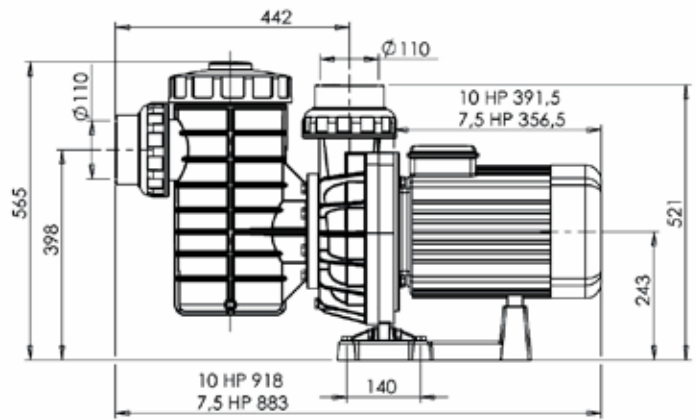
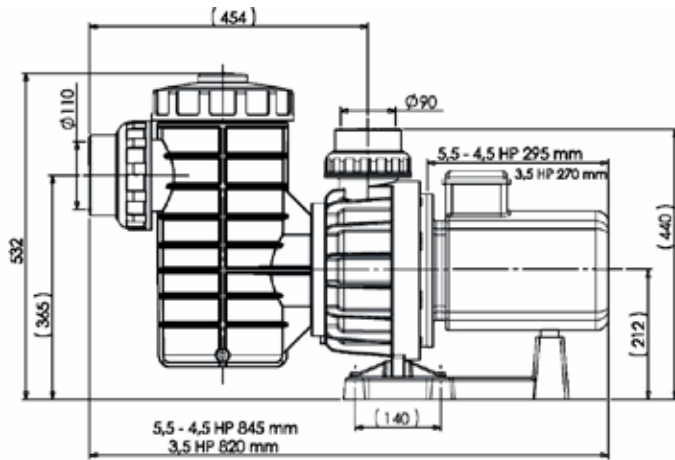
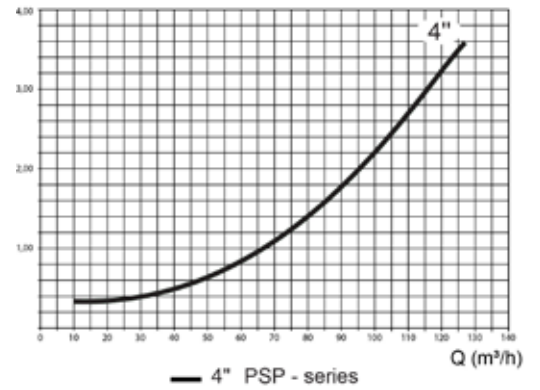

T 0027 (0) 11 392 1177  
www.krepykrauly.co.za

AVAILABLE FROM:

Copyright - Limited License: except as specifically permitted herein, no portion of the content on this document may be reproduced in any form or by any mean without the prior written permission of Pentair

[Automation / Filters / Pumps / Heat Pumps / Cleaners / Sanitizers / Accessories / Water Features](#)

NVA - BR - PSP - SA © 2013 Pentair International SRL. All Rights Reserved. Rev. 03-2014.

